



AT.53

LINEAR ACTUATOR



- ✓ Installed on unwinding and rewinding stations
- ✓ ± 25 mm stroke
- ✓ 1400 N max thrust
- ✓ Available with frontal flange, foot or rod ends bearing
- ✓ Available axial actuators or with gear box shifting

Linear actuators are generally used on unwinding and rewinding stations of compact machines to align the reel perfectly.

AT.53 is the smallest of the AT series and guarantees a stroke of ± 25 mm and a max thrust of 1400 N.

Accordingly to the application it is available with frontal flange, foot or rod ends bearing fixing for an easy installation. Are also available axial actuators or with gear box shifting to reduce the space required or to increase the thrust force. The reed electronic limit switch are inserted in the slots of the stem and are easily accessible in case the operator needs to change the stroke of the actuator.

All parameters and set up of the actuators are easily managed by the operator using the MWG10.1 controller.

AT.53.A

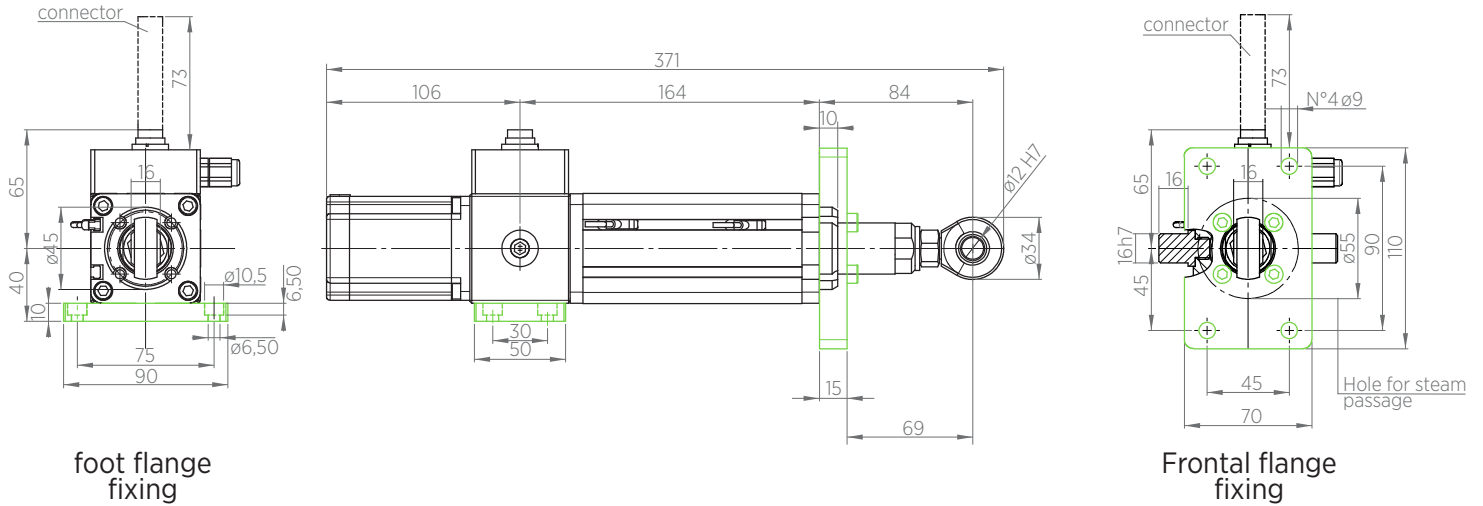

AT.53.R

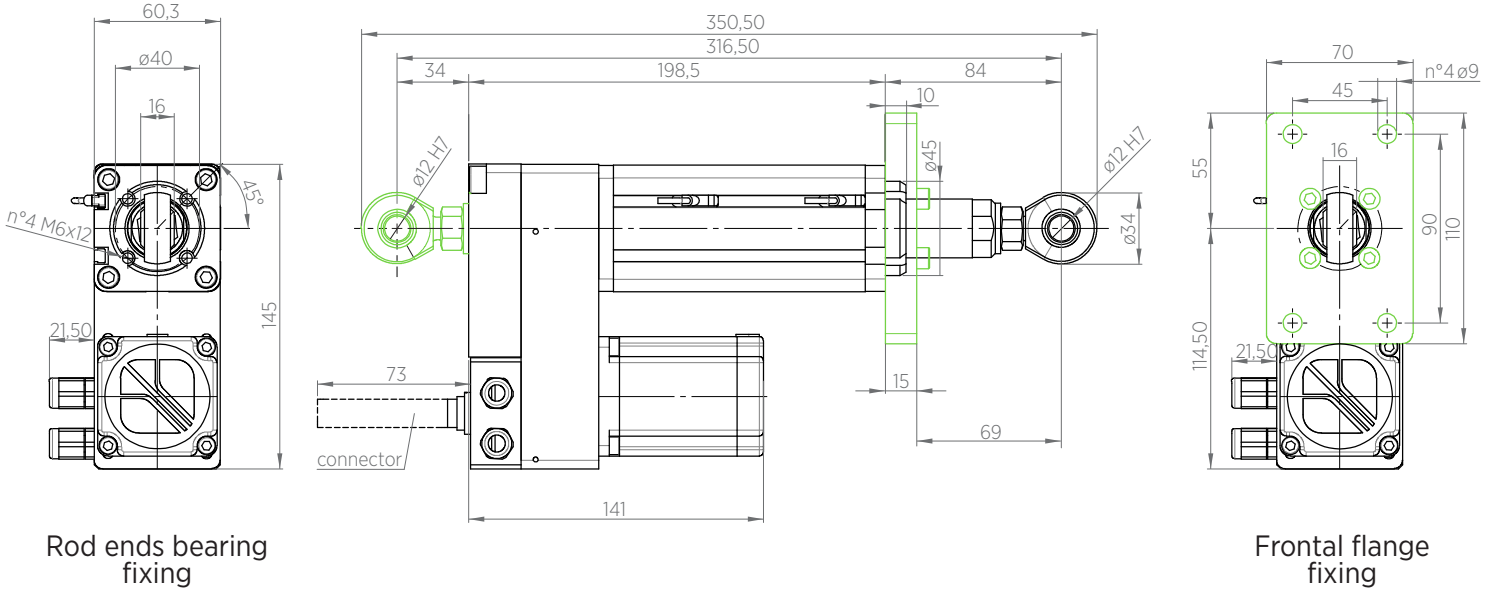

TECHNICAL CHARACTERISTICS

	AT.53.A	AT.53.R
Power supply	24 Vdc	24 Vdc
Power consumption	4 A	4 A
Stroke	± 25 mm	± 25 mm
Min speed	6 mm/s	4,5 mm/s
Max speed	90 mm/s	75 mm/s
Max thrust	1100 N	1400 N
Thrust at 20 mm/s	650 N	800 N
Working temperature	10÷50° C	10÷50° C

*Data are subject to technical change without notice