



B.55

ELECTROMAGNETIC POWDER BRAKE



- ✓ Compact design
- ✓ High precision
- ✓ Zero dust emission
- ✓ Long life span
- ✓ 0,04 Nm residual torque
- ✓ 5 Nm torque

Since more than 30 years the Eleflex electromagnetic powder brake series is one of our well known products.

The experience gained during years, thousands of applications, the constant research into materials and the studies carried out on brakes performance, have allowed us to increase our know how and to continually improve our product.

Eleflex brakes guarantee small size, high precision of the torque control, no dust emissions and reduced residual torque.

Thanks to a special design, Eleflex brakes can lower the residual magnetism and the mechanical friction, bringing down the residual torque to less than 1% of the nominal torque.

B.55 is a mini model Eleflex brake and is usually used in the textile and metal wire sectors where low web tension and precise control of the tension are required.

TECHNICAL DRAWING

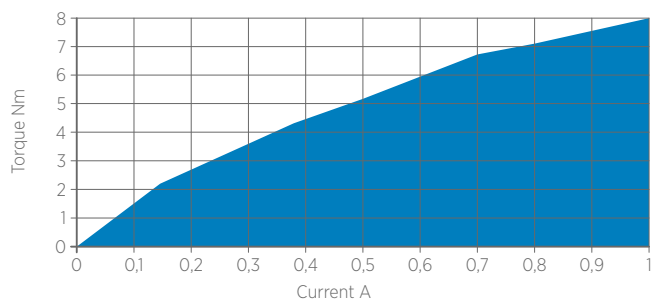
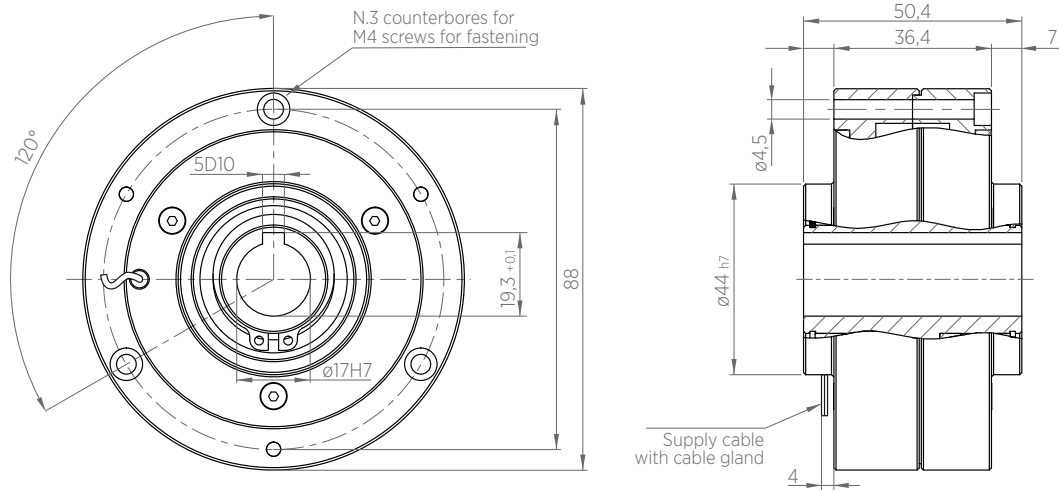

Functioning

The electromagnetic powder brake is made up of three basic components: the coil, the stator and the rotor. When current is supplied to the brake, the magnetic field inside the coil starts to vary in proportion to the intensity of the current. The variation in the magnetic field alters the viscosity of the special powder positioned between the rotor and the stator.

TECHNICAL CHARACTERISTICS

Torque	5 Nm
Residual torque	0,04 Nm
Max current	1 A
Resistance at 20° C	24 Ohm
Voltage (PWM)	24 V
Power dissipation	75 W
Rpm min/max	40/2000 rpm
Weight	1,3 kg

*Data are subject to technical change without notice

** Torque values relate to dynamic slipping